

88 6101-02 Stackable Storage

X

Door Unit

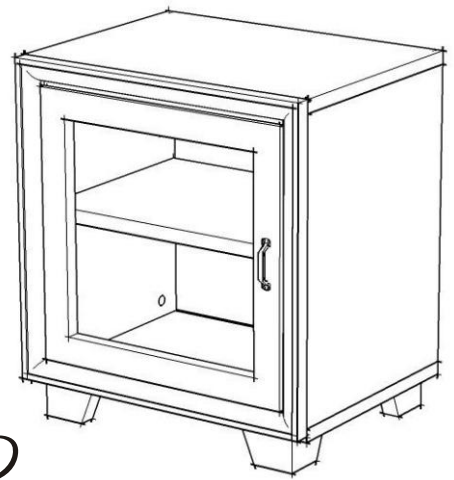

IMPORTANT NOTE

Carefully remove all the parts from the carton and put them individually on a soft cloth to prevent scratches or other damages occurring to the wood parts.

We have taken great care in the design of this product and request that you carefully and strictly follow our assembly instructions to ensure a completed product as it was designed.



Casual Attire For Today's Home

Part List

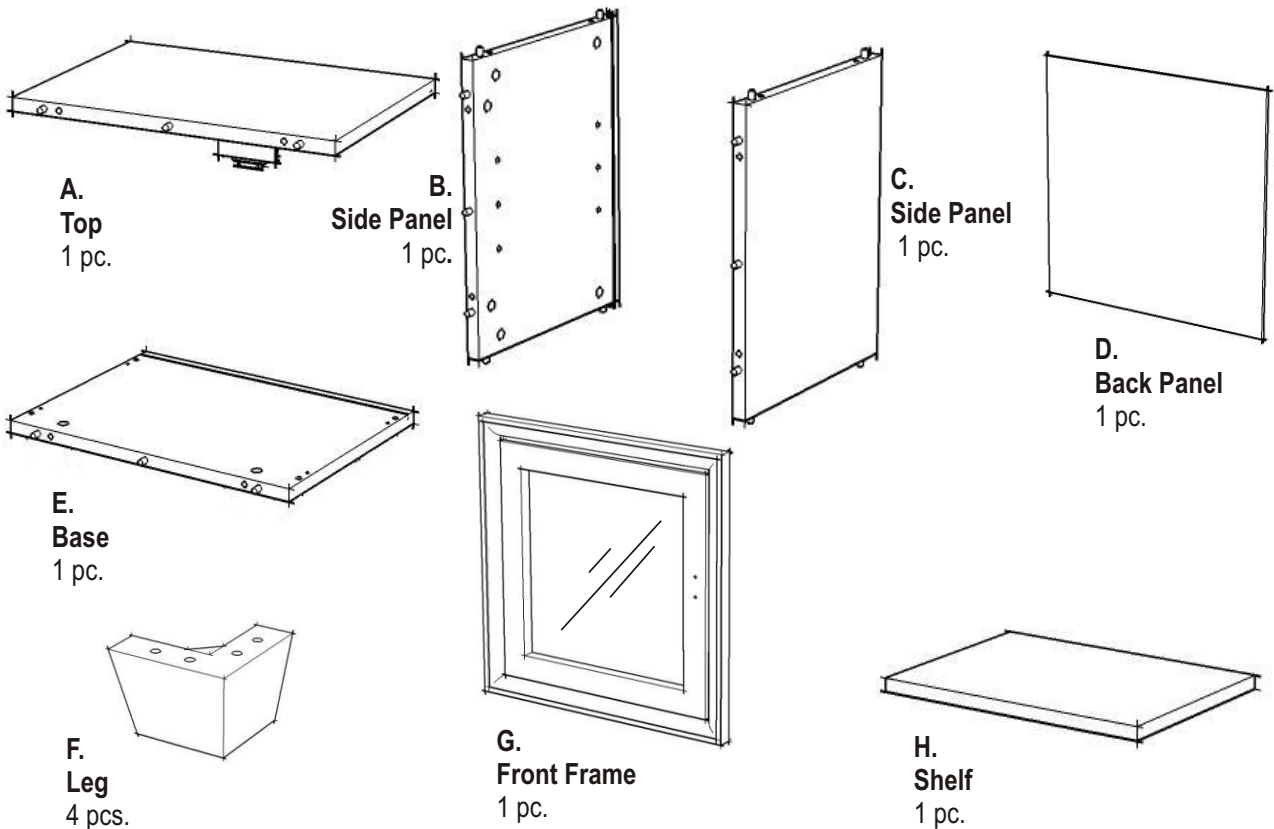

Hardware List

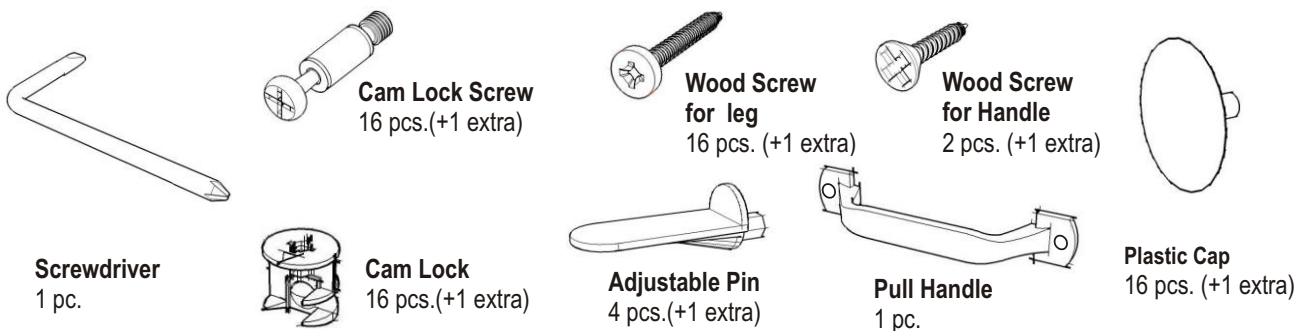

Assembly Instructions 2/3

IMPORTANT

Do not tighten up all the screws until each part is properly assembled.

You should keep Hex Wrench in the safe place as you may need to tighten up the Head Cap Bolts in the future.

STEP 1

Insert Cam Lock Screws into the pre-drilled holes of Top (A) and Base (E).

Attach Side Panel (B) and (C) to Top (A) with Cam Locks.

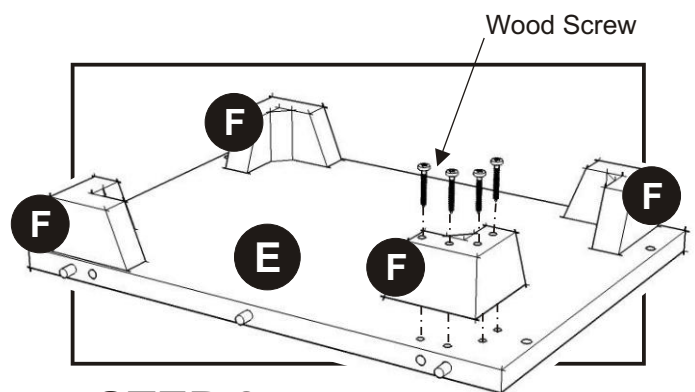
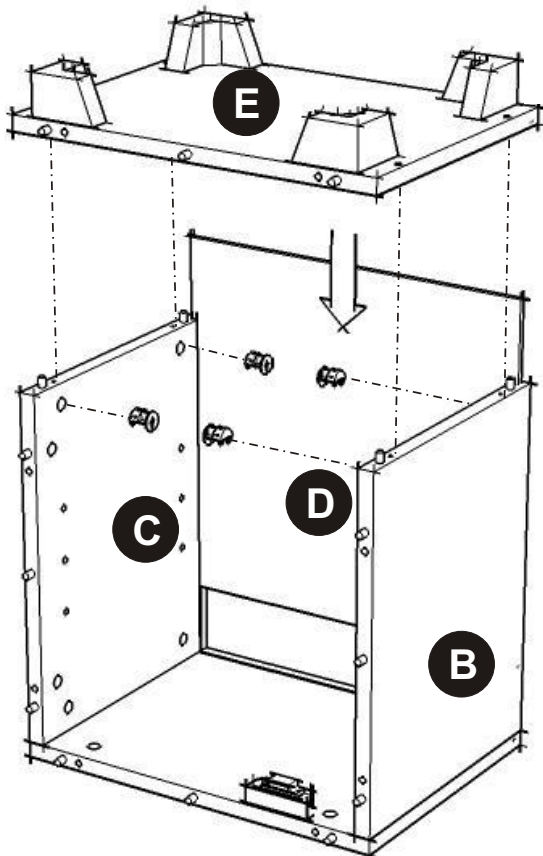
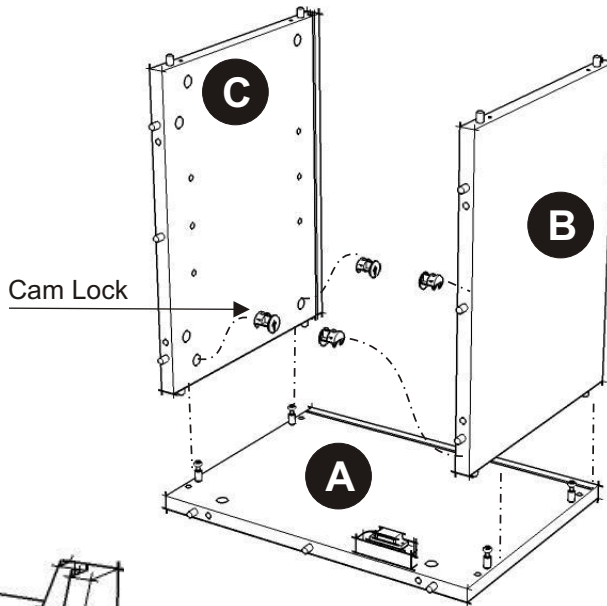
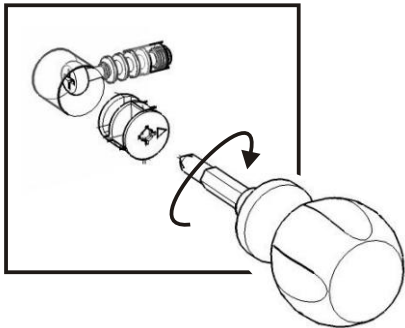
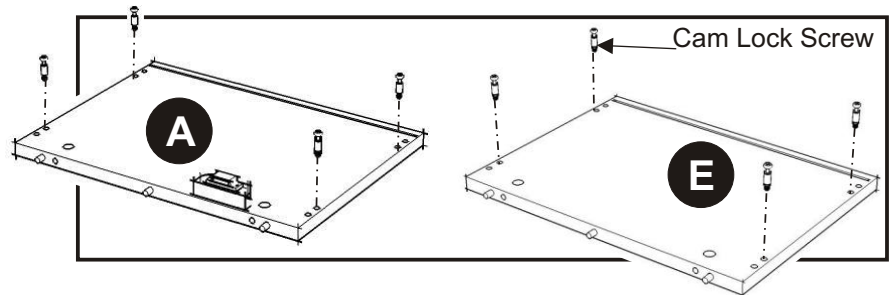

STEP 2

Attach the Leg (F) to Base (E) with Wood Screws.

Note : If you need to overlie the storage, don't assembly the legs.

Slide Back Panel (D) into the unit.

Attach Base (E) onto the unit with Cam Locks.

Assembly Instructions 3/3

STEP 3

Insert Cam Lock Screws into the pre-drilled holes of Front Frame (G).

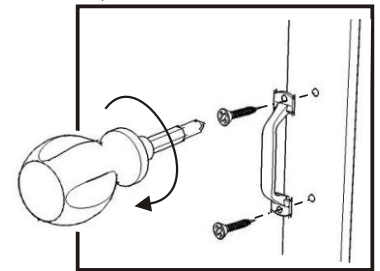
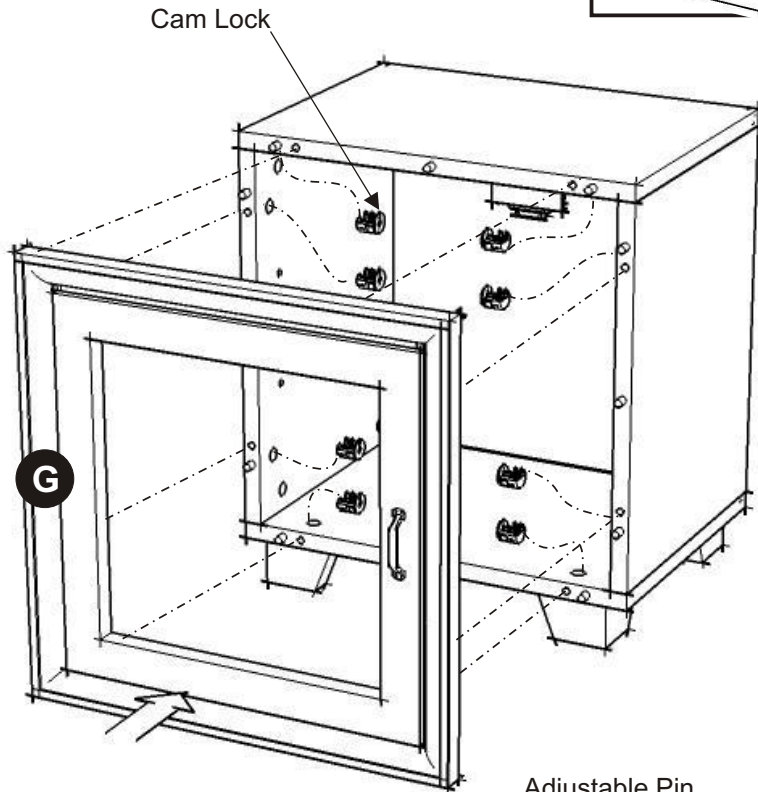
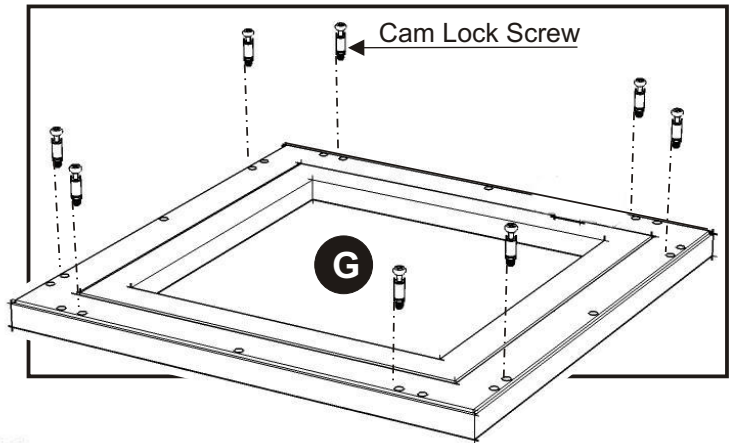

STEP 4

Figure 1

Turn the unit back to its normal position.

Attach the Pull Handle to the door with Wood Screws. (See figure 1)

Attach Front Frame (G) to the unit, using Cam Locks.

STEP 5

Insert Adjustable Pins into the side panels at the desired level.

Place Shelf (H) into position.

Cover up Cam Lock's holes with Plastic Caps. (See figure 2)

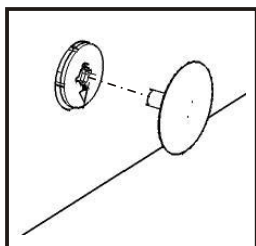

Figure 2

