

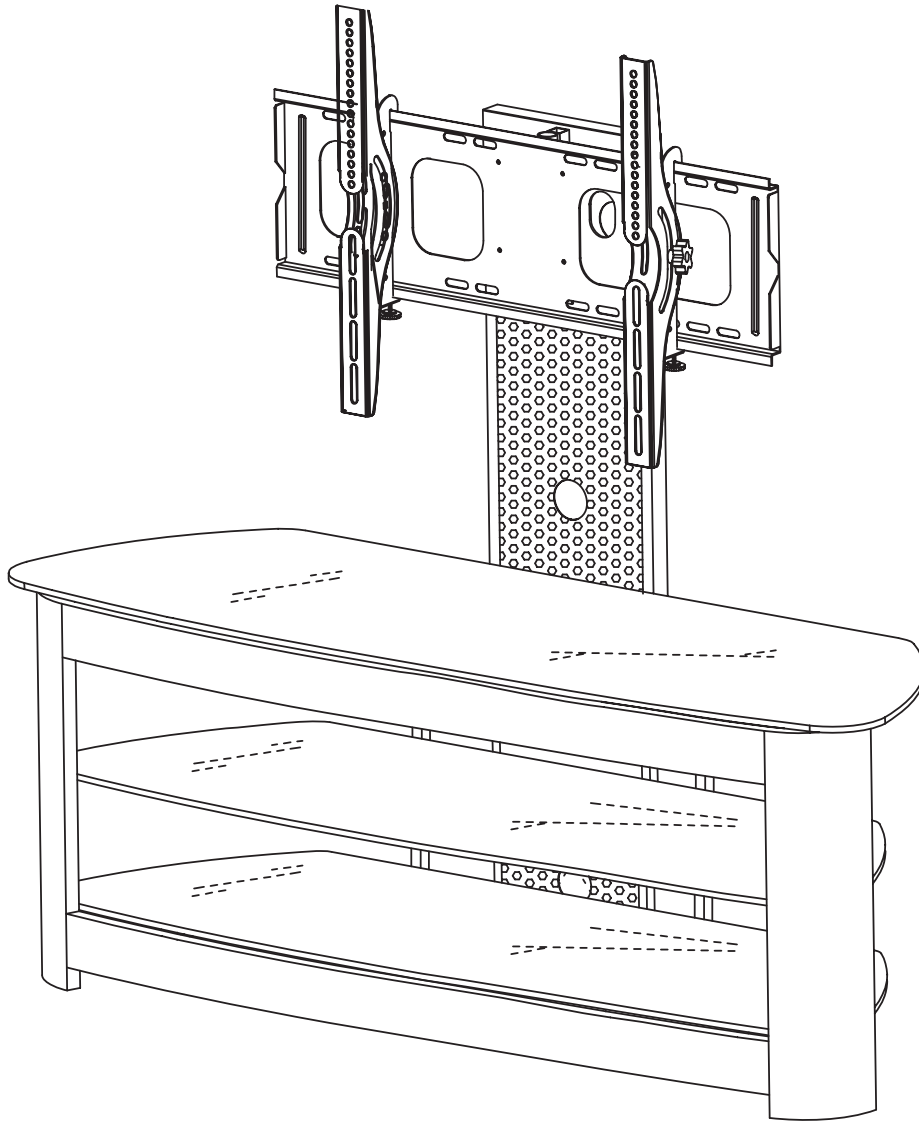

## Assembly Instructions

Regal 60" TV Stand - V60MWF



Includes 3 configurations:

TV Stand • TV Mount Stand • TV Wall Mount & Component Stand

an *SefaCo.* Store

1-877-275-9111

# PARTS LIST

A  L QTY 1	B  R QTY 1	C  QTY 1	D  QTY 1	E  L QTY 2
F  R QTY 2	G  QTY 1	H  QTY 1	I  QTY 1	J  QTY 1
K  QTY 2	L  1473*460*8.0mm QTY 1	M  1348*387*8.0mm QTY 1	N  1348*387*5.0mm QTY 1	

## HARDWARE LIST

1  QTY 8	2  QTY 8	3  1/4"*1/2" QTY 16	4  16mm QTY 35	5  QTY 8	6  QTY 4	7  1/4"*2" QTY 6	8  QTY 4	9  QTY 2
10  QTY 2	11  QTY 2	12  4.0mm QTY 1	13  QTY 1	14  1/4"*3/4" QTY 5	15  1/4"*7/8" QTY 4			

## TV Mounting Hardware List:

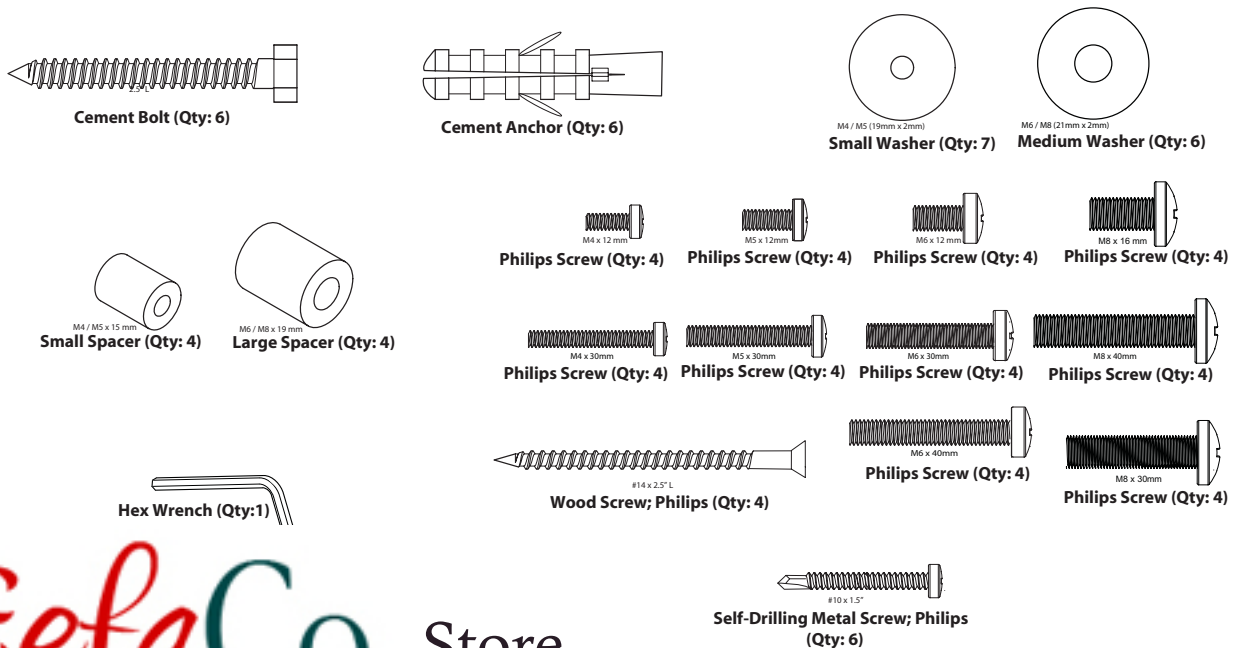

You can assemble this stand in three (3) different configurations depending on your personal preference. Each of these configurations are outlined below with the appropriate assembly steps required. Each required step will have the appropriate icon of the configuration for your reference.

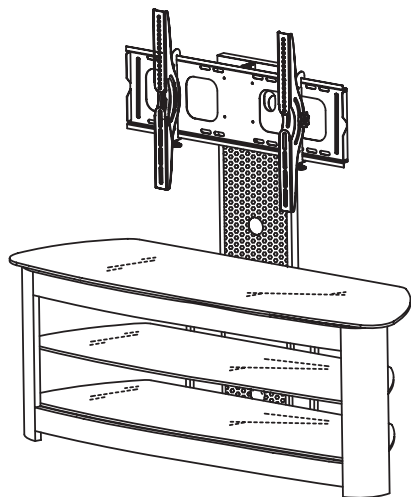

**Configuration 1 - TV Mount on Stand**

To build this, follow steps 1 through 9.

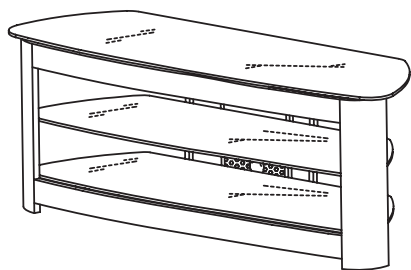

**Configuration 2 - TV Stand Only**

To build this, follow steps 1 through 3, then jump to step 9.

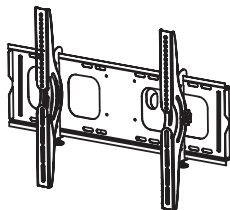

**Configuration 3 - TV Wall Mount & Component Stand**

To build this, follow steps 1 through 3, then jump to step 9. Follow steps 7 and 8. Follow step 10 for attaching mount to wall.

an *EefaCo.* Store  
1-877-275-9111

## STEP 1

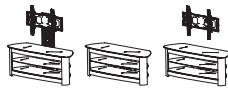

Screw cam bolts (1) into legs (A & B). Insert cam locks (2) into front panels (C & D).

Insert legs into front panels as shown in the diagram.

Tighten cam locks (2) using a screwdriver (*screwdriver not included*).

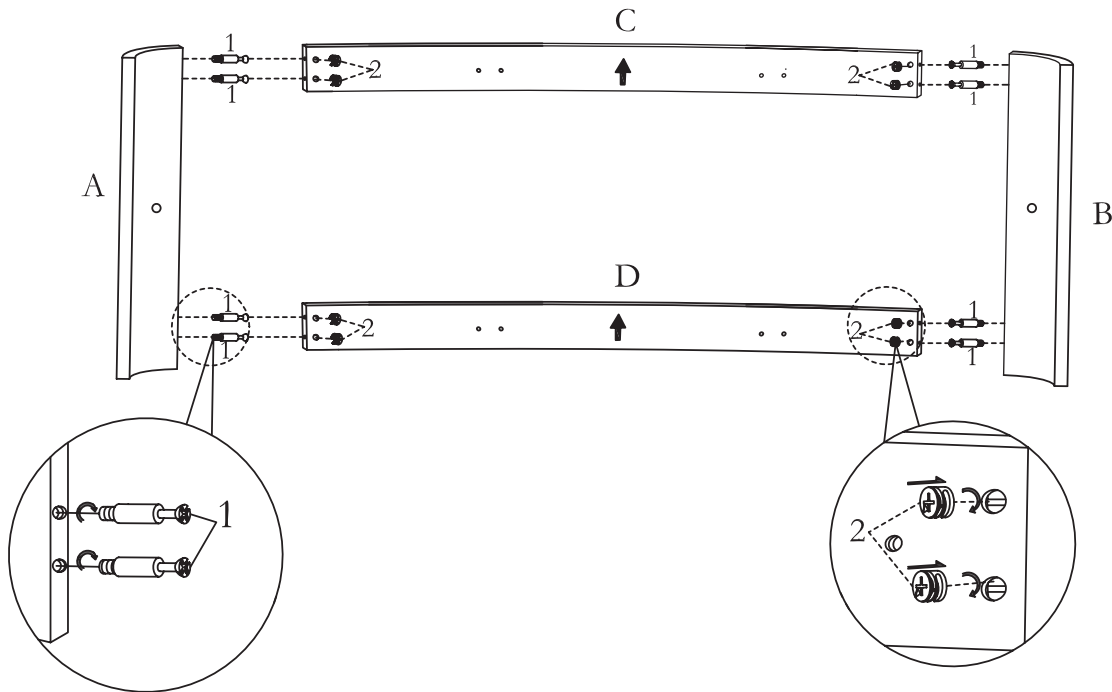

## STEP 2

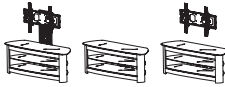

Attach cross bars (E & F) to front panels using screws (3) and washers (4).

Attach cross bars (E & F) to lower cable management system (G) using screws (3) and washers (4)

Tighten screws using hex wrench (12).

an **SefaCo.** Store  
1-877-275-9111

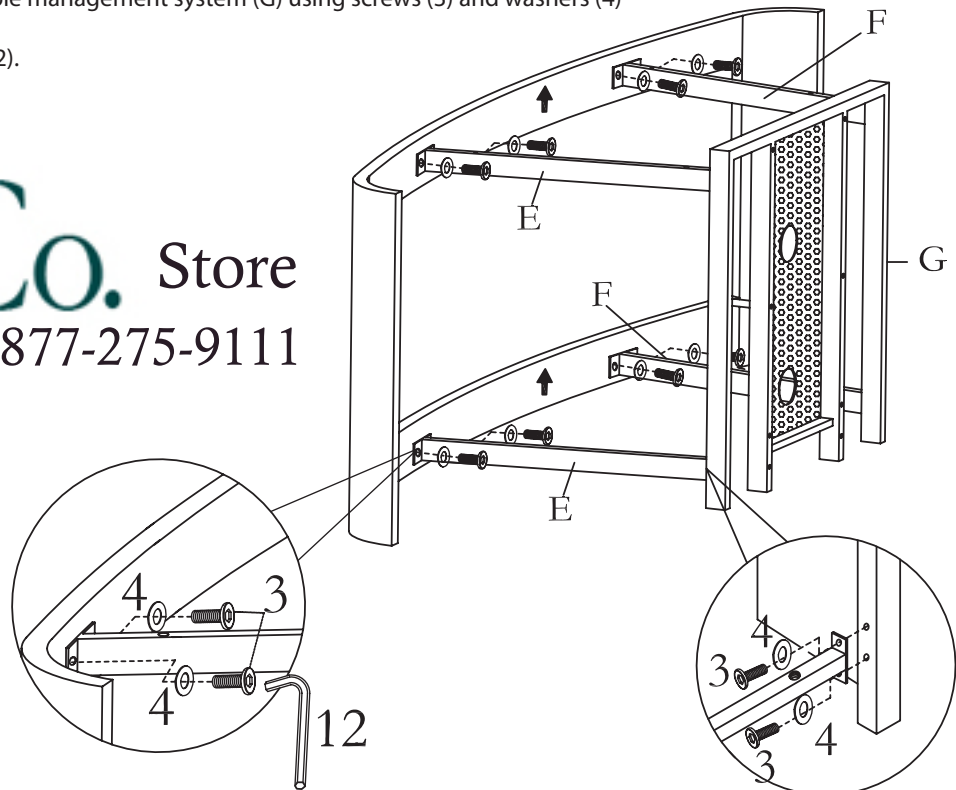

### STEP 3

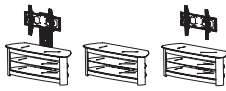

Screw suction cups (5) into the cross bars as shown in the diagram.

Insert rubber pads (9) into the legs as shown in the diagram.

Screw glass support pins (6) into the front legs and lower cable management as shown in the diagram.

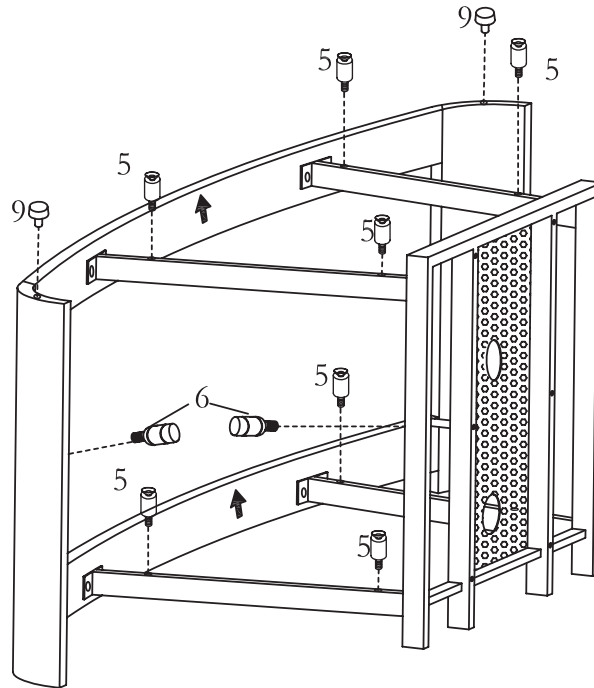

### STEP 4



Attach upper cable management system (H) to lower cable management using screws (7) and washers (4).

Tighten using hex wrench. *Be sure to tighten firmly.*

an **EefaCo.** Store  
1-877-275-9111

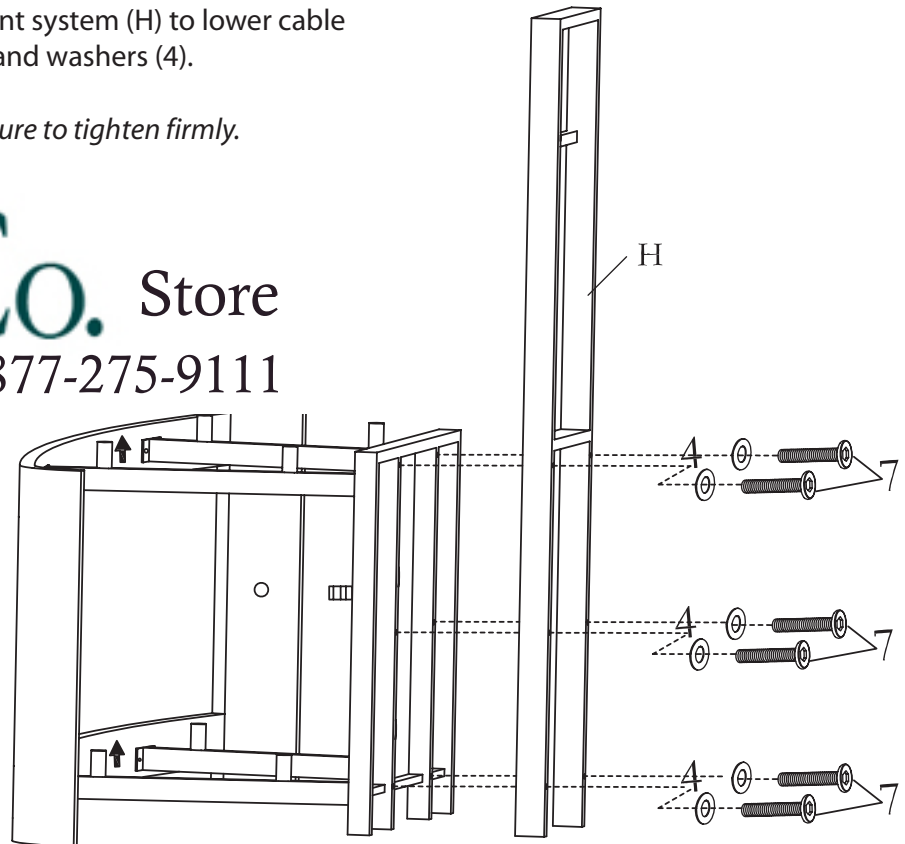

## STEP 5



Attach pivoting bracket (I) to the upper cable management system (H) using screws (14) and washers (4) as shown in the diagram.

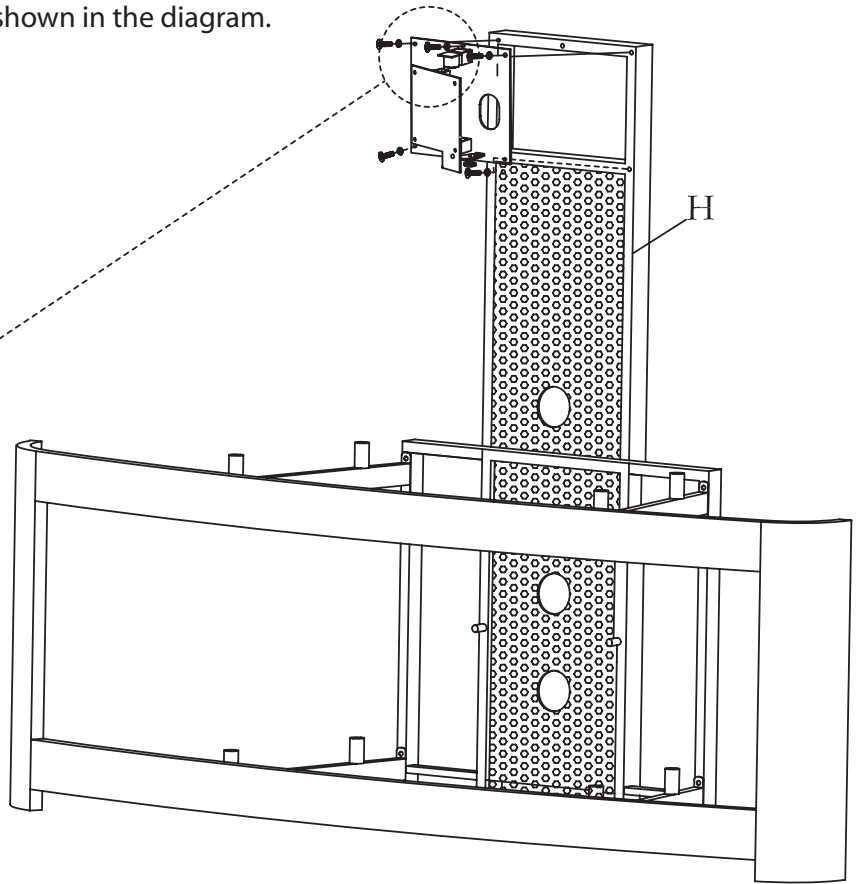
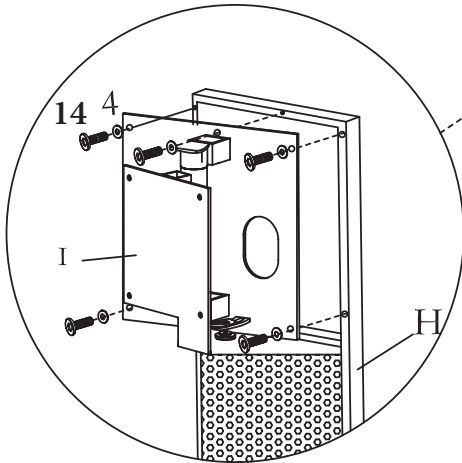

## STEP 6



Attach mount bracket base (J) to the pivoting bracket using screws (15) and washers (4) fastened on the back side using nuts (8) and washers (4) as shown in the diagram.

Tighten using the provided wrenches (13 & 12). *Be sure to tighten firmly.*

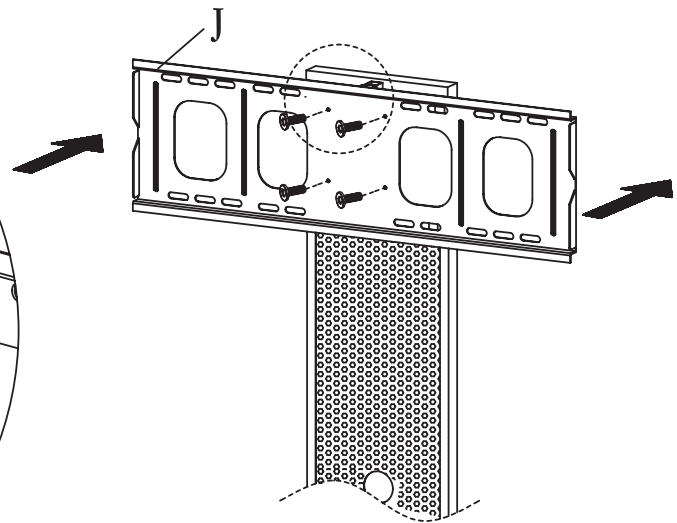
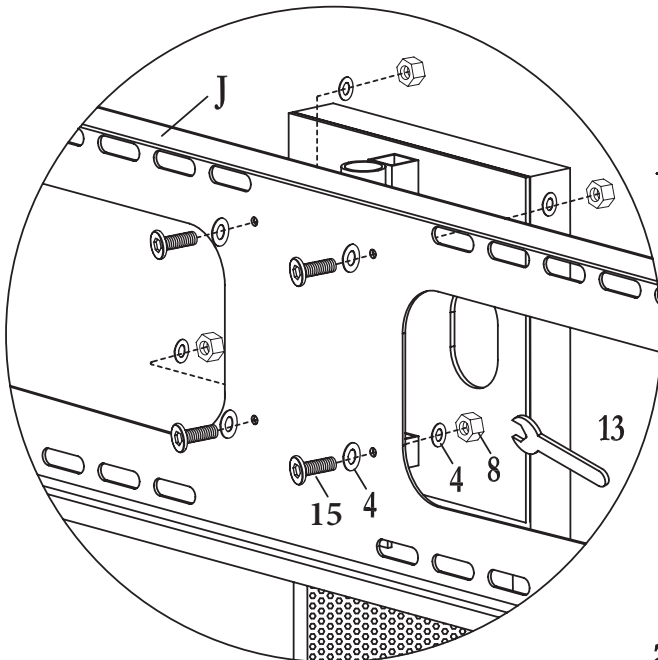

## STEP 7

Insert bolts (11) into the square hole on the inner part of tilting brackets (K).

Screw adjustment knobs (10) onto bolts (11).

Attach tilting brackets (K) to your TV as shown. Select the appropriate size of screws, washers, and spacers (if necessary) for your type of TV. *Hardware required will vary depending on your TV.*

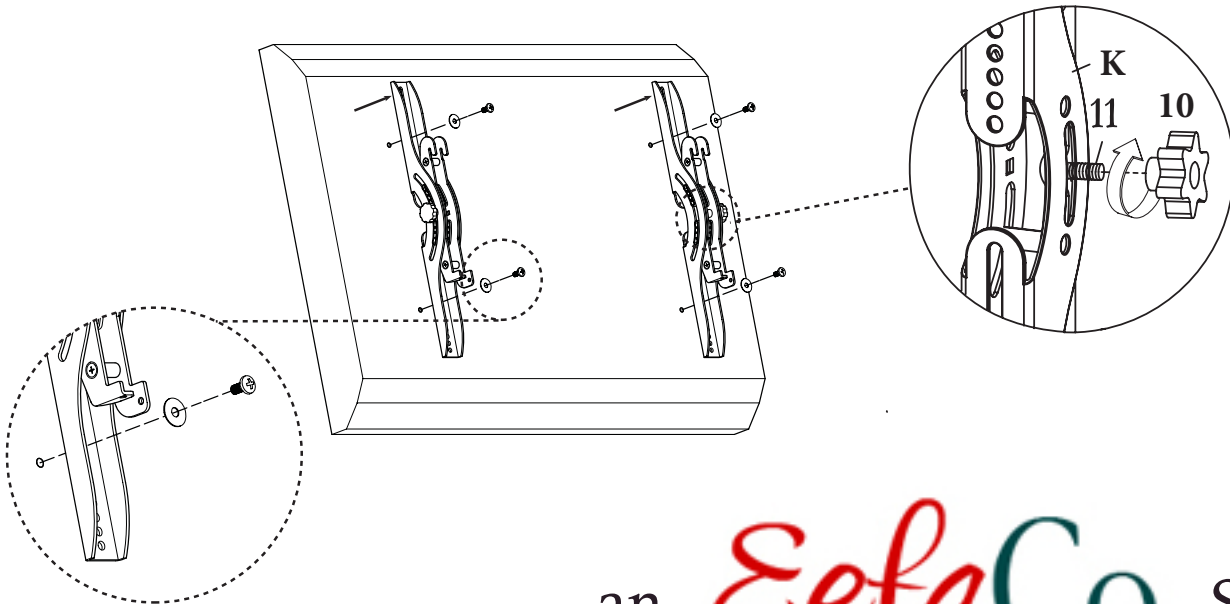

an **EefaCo.** Store  
1-877-275-9111

## STEP 8

Carefully hook tilting brackets (K) on to the grooves on the mount bracket base (H) as shown in the diagram. *Two people are recommended for this step!*

Once the TV is securely positioned on the mount bracket, tilt the TV into desired position. Tighten the tilt adjustment knobs (10). Then tighten the adjustment knob on the bottom of tilting bracket (K) to secure TV in place.

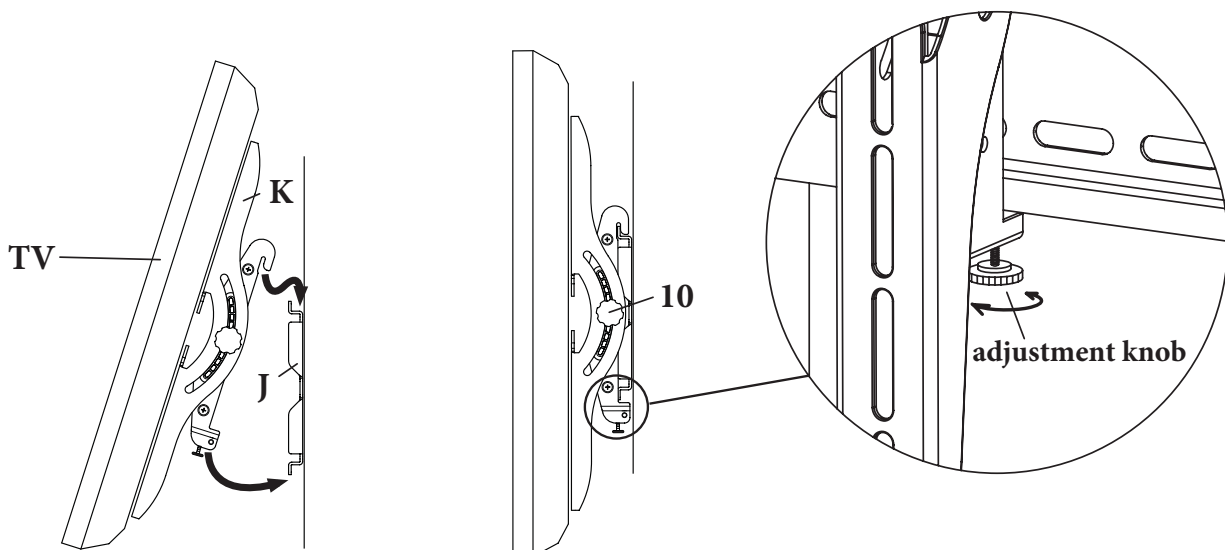

## STEP 9

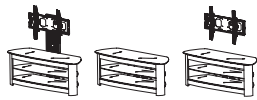

Place top glass (L) carefully into position on top of the stand as shown in the diagram.

Slide middle glass (M) carefully into position and from the side as shown in the diagram.

Slide bottom glass (N) carefully into position and from the side as shown in the diagram.

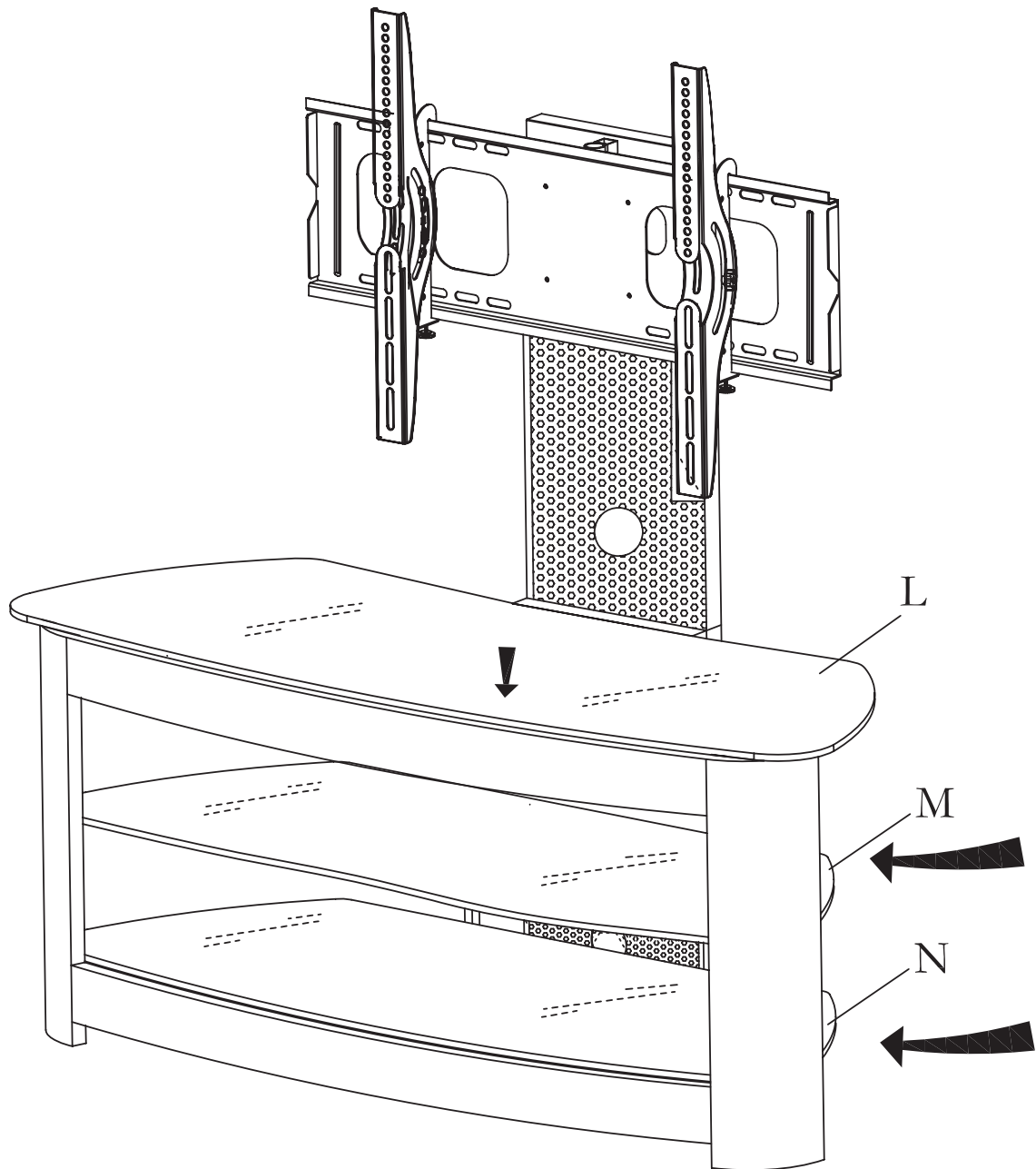

## STEP 10

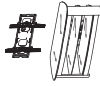

### TV Wall Mount Installation

To attach the mount to the wall, use only wall screws and plugs (if needed) suitable for the particular wall type. Due to the wide variety of wall types, we cannot describe them all here. However, we have included illustrations showing installation for some common wall types. **You must mount to the structure of the wall, i.e. wood studs, metal studs, or cement/brick directly. DO NOT attach to the surface of the wall without anchoring into the structural framework of the wall.** Some hardware for attaching to the wall has been included, and additional screws and plugs are available from any hardware store if needed. Please seek professional advice if you are unsure of your own ability to do this correctly. Walker Edison makes no representation of warranty, expressed or implied, to the strength of any type of wall structure and the wall's ability to hold your TV. You assume all responsibility and indemnify Walker Edison of any and all damages that may be incurred with mounting your TV to the wall.

#### Cement/Brick

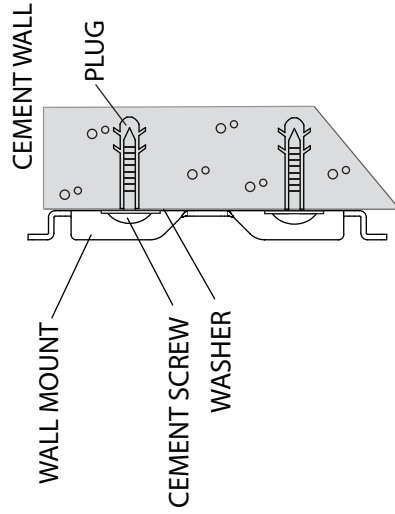

#### Metal Studs

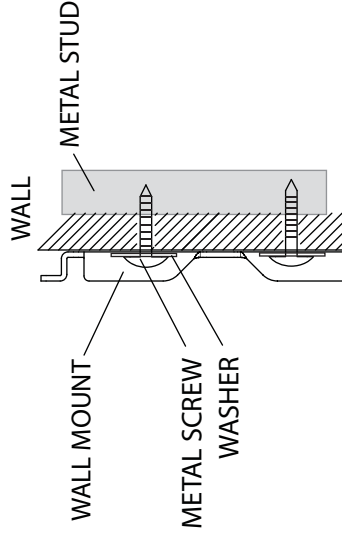

#### Wood Studs

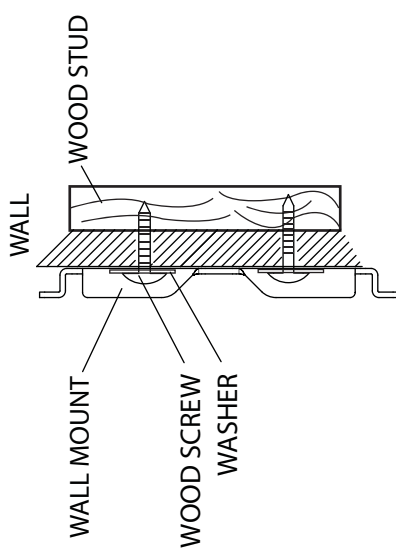

an **SefaCo.** Store  
1-877-275-9111

Walker Edison Furniture Co., intends to make these instructions accurate and complete. However, Walker Edison makes no claim that the information contained herein covers all details, conditions, or variations. Nor does it provide for every possible contingency in connection with the installation or use of this product. The information contained in this document is subject to change without notice or obligation of any kind. Walker Edison makes no representation of warranty, expressed or implied, regarding the information contained herein. Walker Edison assumes no responsibility for accuracy, completeness or sufficiency of the information contained in this document.